



## Chopper 3300 HSK S5A

### Pneumatic taper change

Item no. **11505003**

HF-Spindle for high-speed milling, -grinding, -drilling, -engraving

### Bearings

Steel ball bearing (pcs)	3
Lifetime lubricated	maintenance free

### Motor

Motor technology	3-phase asynchronous drive (no brushes or sensors)
Acceleration/braking value Per second	10.000 rpm (other values by consultation)
Frequency	500 Hz
Motor poles (pairs)	1
Rated rotation speed	30.000 rpm

### Power values

Fan cooled

	Pmax./5s	S6-60%	S1-100%	
Rated power	7,5	4,5	3,3	[kW]
Torque	2,9	1,5	1,1	[Nm]
Voltage	380	380	380	[V]
Current	19	9,1	6,8	[A]

## Chopper 3300 HSK S5A

Pneumatic taper change

Item no. **11505003**

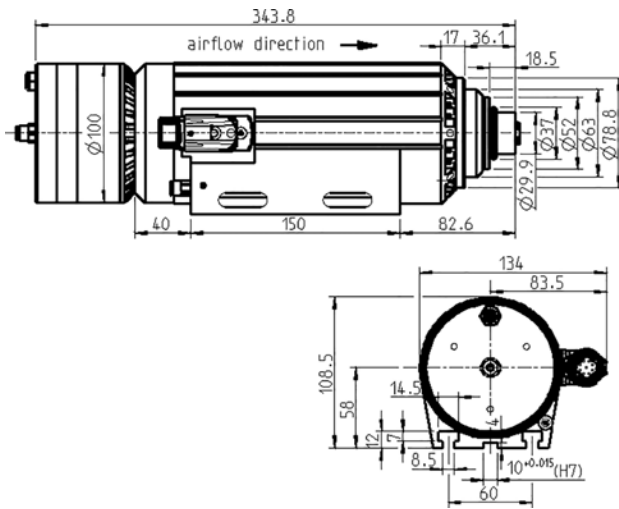

Dimensions

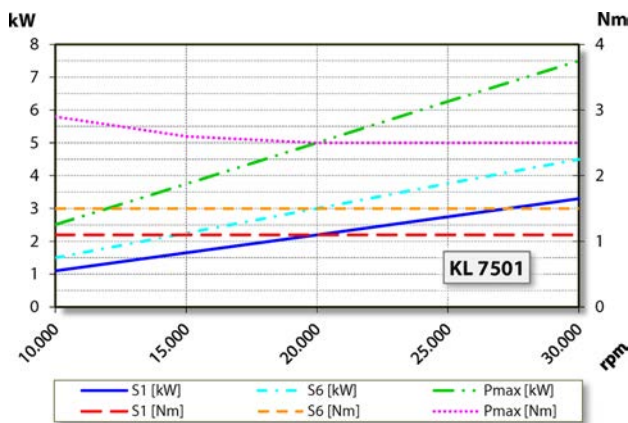

Performance Diagram

Fan cooled

Measurement of power is funded by in-house testing.

## Characteristics

Motor protection	PTC 130°C
Housing	Aluminium
Housing diameter	100 mm
T-slots	DIN 650-8
Spindle holder integrated	
Cooling	Fan-cooled (impeller on shaft)
Heat dissipation	Via the housing
Housing temperature	< + 55° C
Ambient temperature	+ 10°C ... + 45°C
Sealing air	
Protection category (sealing air turned on)	IP54
Taper cleaning	
ESD protection	
Tool change	Pneumatic taper change
Tool Holder	HSK-E 32
Clamping range up to	13 mm
Clockwise	
Coupler plug	9-pin (SpeedTEC)
Weight	~ 9,4 kg
Inner taper run out	< 2 μ
Axial run-out	< 2 μ